

螺纹外测千分尺

←INSIZE→PLUS



3680-50



3680-4001

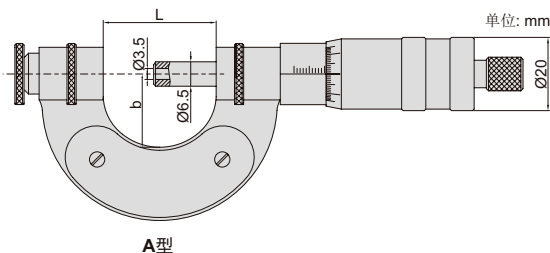

A型

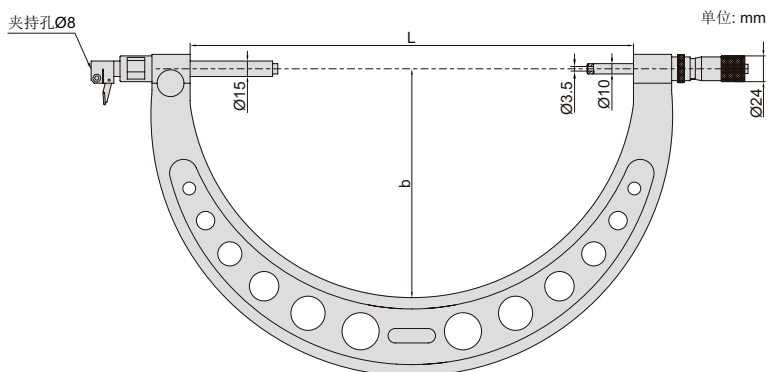

B型

- 符合JJG螺纹千分尺国家计量检定规程
- 用于测量螺纹中径
- 分度值: 0.01mm
- 可选附件: 外螺纹测头(7390系列), 标准杆(7384系列), 数显或机械千分表(仅适用于B型)

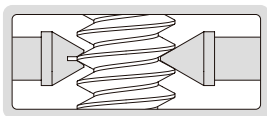

A型(棘轮测力)

(mm)

| 型号 | 测量范围 | 精度 | L | b |
|-----------|-----------|-----|-----|-----|
| 3680-25* | 0-25mm | 4μm | 37 | 24 |
| 3680-50* | 25-50mm | 4μm | 62 | 34 |
| 3680-75* | 50-75mm | 4μm | 87 | 46 |
| 3680-100* | 75-100mm | 4μm | 112 | 60 |
| 3680-125* | 100-125mm | 5μm | 139 | 72 |
| 3680-150* | 125-150mm | 5μm | 164 | 85 |
| 3680-200* | 150-200mm | 7μm | 215 | 110 |
| 3680-250* | 200-250mm | 7μm | 264 | 135 |
| 3680-300* | 250-300mm | 7μm | 315 | 160 |

*带生产厂检验证书

B型(无棘轮测力)

(mm)

| 型号 | 测量范围 | 测头缩进量 | 微分头精度 | L | b |
|-------------|-------------|-------|-------|------|------|
| 3680-3001* | 200-300mm | 2.5mm | 6μm | 320 | 165 |
| 3680-4001* | 300-400mm | 2.5mm | 7μm | 430 | 220 |
| 3680-5001* | 400-500mm | 2.5mm | 8μm | 530 | 273 |
| 3680-6001* | 500-600mm | 2.5mm | 9μm | 630 | 323 |
| 3680-7001* | 600-700mm | 2.5mm | 9μm | 730 | 378 |
| 3680-8001* | 700-800mm | 2.5mm | 9μm | 830 | 423 |
| 3680-9001* | 800-900mm | 2.5mm | 10μm | 930 | 473 |
| 3680-10001* | 900-1000mm | 2.5mm | 10μm | 1030 | 520 |
| 3680-4002* | 200-400mm | 2.5mm | 7μm | 430 | 220 |
| 3680-6002* | 400-600mm | 2.5mm | 9μm | 630 | 323 |
| 3680-8002* | 600-800mm | 2.5mm | 9μm | 830 | 423 |
| 3680-10002* | 800-1000mm | 2.5mm | 10μm | 1030 | 520 |
| 3680-12002* | 1000-1200mm | 2.5mm | 11μm | 1230 | 635 |
| 3680-14002* | 1200-1400mm | 2.5mm | 12μm | 1430 | 735 |
| 3680-16002* | 1400-1600mm | 2.5mm | 18μm | 1660 | 840 |
| 3680-18002* | 1600-1800mm | 2.5mm | 20μm | 1870 | 940 |
| 3680-20002* | 1800-2000mm | 2.5mm | 22μm | 2075 | 1055 |